

Adept Viper™ s1700

Specifications

Reach	1717 mm
Payload (max)	20 kg
Joint Range	
Joint 1	± 180 °
Joint 2	-200 °, +65 °
Joint 3	+35 °, +190 °
Joint 4	± 200 °
Joint 5	± 140 °
Joint 6	± 360 °
Inertia Moment (max)	
Joint 4	0.7 kgm ²
Joint 5	0.7 kgm ²
Joint 6	0.2 kgm ²
Composite Speed (max)	
	8,400 mm/sec
Joint Speeds	
Joint 1	170 °/sec
Joint 2	170 °/sec
Joint 3	175 °/sec
Joint 4	335 °/sec
Joint 5	345 °/sec
Joint 6	525 °/sec
Repeatability (XYZ)	± 0.060 mm
Pass-Through User Connections (routed from robot base to outer link)	
Electrical	16
Pneumatic	1
Brakes	All Axes
Internal Solenoids	None (User supplied)
Ingress Protection	IP54
Mounting	Floor/Table
Weight	280 kg



The Adept Viper 6-axis robot family is a high-performance line of robots designed for a wide variety of applications. The speed and precision of the Adept Viper robots make them ideal for assembly, material handling, packaging, machine tending and many other operations and applications that require fast and precise automation. The Adept Viper s1700 six-axis robot is an extended-reach and higher payload robots that complement the Viper product family.

Product Features

- Extended reach with 20 kg payload
- V+ real time - multitasking operating system
- Programming software AdeptWindows or Adept Desktop
- SmartServo™ controls ensure superior path following and control
- AdeptVision™ provides added flexibility and lowers integration costs
- Adept SmartController CX high-performance robot and integrated vision controller
- Absolute encoders make for easy calibration
- High-resolution encoders provide high-precision and superior slow-speed performance
- High-efficiency motors deliver high performance with more torque per amp

- Complete interchangeability between robots and controllers
- Integrated diagnostic display for fast troubleshooting on sDAI
- Control of external auxiliary axes
- Dual configuration

Benefits

- Ensures system reliability and high production uptime
- Increases productivity
- Enables higher product mix and changeover
- Reduces integration costs
- Accelerates time to market
- Provides increased flexibility and accuracy through integrated vision guidance.

Adept Viper™ s1700

Dimension Adept Viper s1700 (mm)

- Work Envelope:
 Radius 1700 mm
- Inner Limit:
 Radius 404 mm
- Recommended Wall Distance:
 189 mm

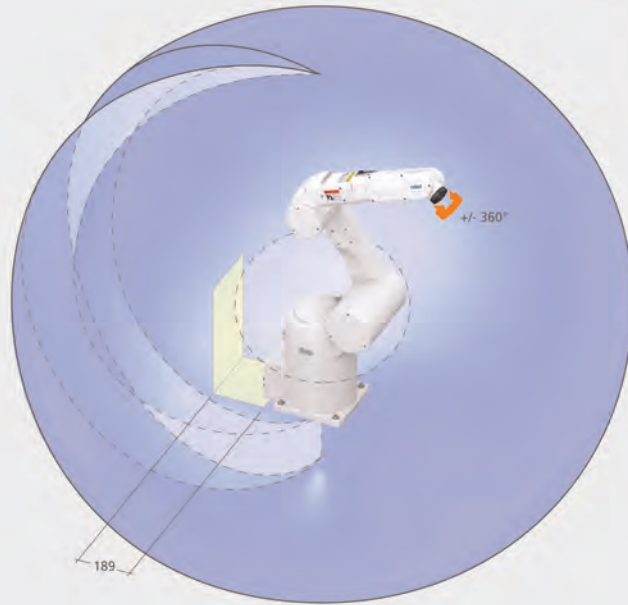

Dimension Flange (mm)

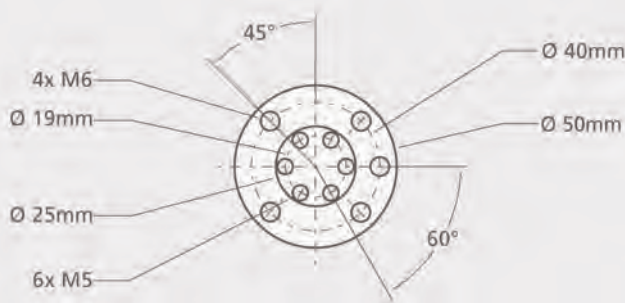

Dimension foot plate (mm)

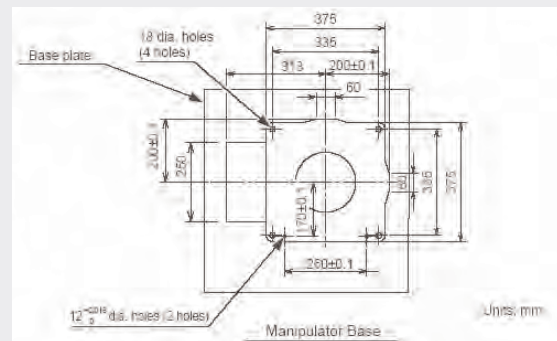

The Adept Viper s1700 system includes the following:

- Adept Viper s1700 robot
- Adept SmartController CX (with software installed)
- PA-4 Chassis with servo controller and amplifiers
- Front Panel with E-Stop
- 7-Meter Robot Cable
- AdeptWindows Software
- Network File Server (NFS) software
- Ethernet TCP/IP capability
- User Documentation

The user must supply the following items:

- Power to SmartController and PA-4 Amplifier Chassis (see power requirements)
- Cell-based emergency stop wiring
- Windows™-based PC (not required at run-time)



Adept Technology, Inc. 3011 Triad Drive, Livermore, CA 94551

Tel: 925-245-3400 Fax: 925-960-0452 Email: info@adept.com

www.adept.com

©2006 Adept Technology, Inc. All rights reserved. Adept and the Adept logo are registered trademarks, and the Adept Viper is a trademark of Adept Technology, Inc. All other trademarks are the property of their respective holders.

AV1700DS0906v1